

## A powerful welding and cladding system that rotates around the work piece.

### High Quality

- The Climax BW5000 AutoBoreWelder with Auto-Skip is an affordable, highly configurable, circumferential weld cladding system, which provides a durable platform for multiple configurations of weld overlay
- The BW5000 rotates around stationary parts. The wire feed, step, and weld wire rotate together under the stationary head unit, retaining consistent wire placement as the machine rotates
- The BW5000 allows for a wide range of exotic alloys with multiple configurations to meet your needs
- The BW5000 utilizes a CLX step feed system, allowing 100% coverage, creating precision welds of any thickness required between 0.125 and 0.35 inches. (3.175 and 8.89 mm)

### Flexible and Dependable Performance

- The modular BW5000 system allows efficient and rapid shifts in various configurations like welding bores, facing outside diameters, and conical seats
- Any commercially available alloy can be used, such as Inconel™, Hastelloy™, Monel™, or stainless steel
- The step process reduces waste while maintaining 100% coverage of the bore and allowing weld overlay thickness to be as large or as small as needed
- Flange faces, gasket surfaces and conical seats can also be welded automatically by utilizing an optional variable angle for conical seats
- The BW5000 can interface with most CV power supplies that are remote interconnect capable, and 350 Amp, 100% duty cycle. Clad transfer modes include GMAW-S (short circuit), GMAW-P (pulse waveform), and FCAW-G (gas shielded flux core). All GMAW transfer modes are supported by the BW5000.

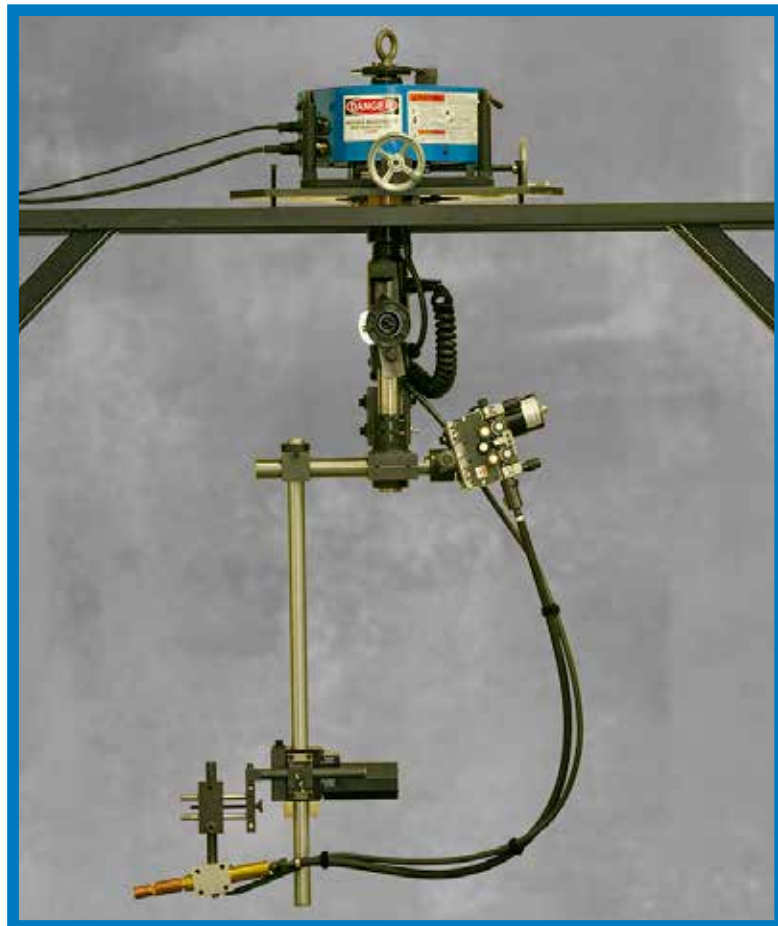

### Minimize Cost, Waste and Downtime

- The BW5000 allows large parts to be welded without rotating them, making it ideal for field work, setting up on large equipment that could never be rotated, and gets the job done 75% faster than traditional hand welding methods.
- After welding operations are complete, the BW5000 packs up to require only 1 cubic yard of storage space.
- The BW5000 can deposit 12 pounds of metal per hour — hour after hour
- Increase both the welding and production capacity
- Build up or clad bores from 12 to 144 inches (304.8 to 3657.6 mm)

# SPECIFICATIONS

	US	Metric
Welding Process	Metal - Inert - gas (MIG) Short Arc, Pulse, or Spray	
Max. Wire Spool Size	2 inches ID x 14 inches OD	50.8 mm ID x 381 mm OD
Stroke	10, 20, 30, 40 and 50 inches	254, 508, 762, 1016 and 1270 mm
ID Diameter Range	12 to 144 inches	304.8 to 3657.6 mm
O.D. Welding Diameter Range	12 to 120 inches	304.8 to 3048.0 mm
Conical Seat Capability:	10 inch stroke	254.0 mm stroke
Capable of tracking conical seats & cones from 12 to 144 inches in diameter		304.8 to 3657.6 mm diameter
Small Bore Diameters	12 inches	304.8 mm

## WELD RANGE INFORMATION

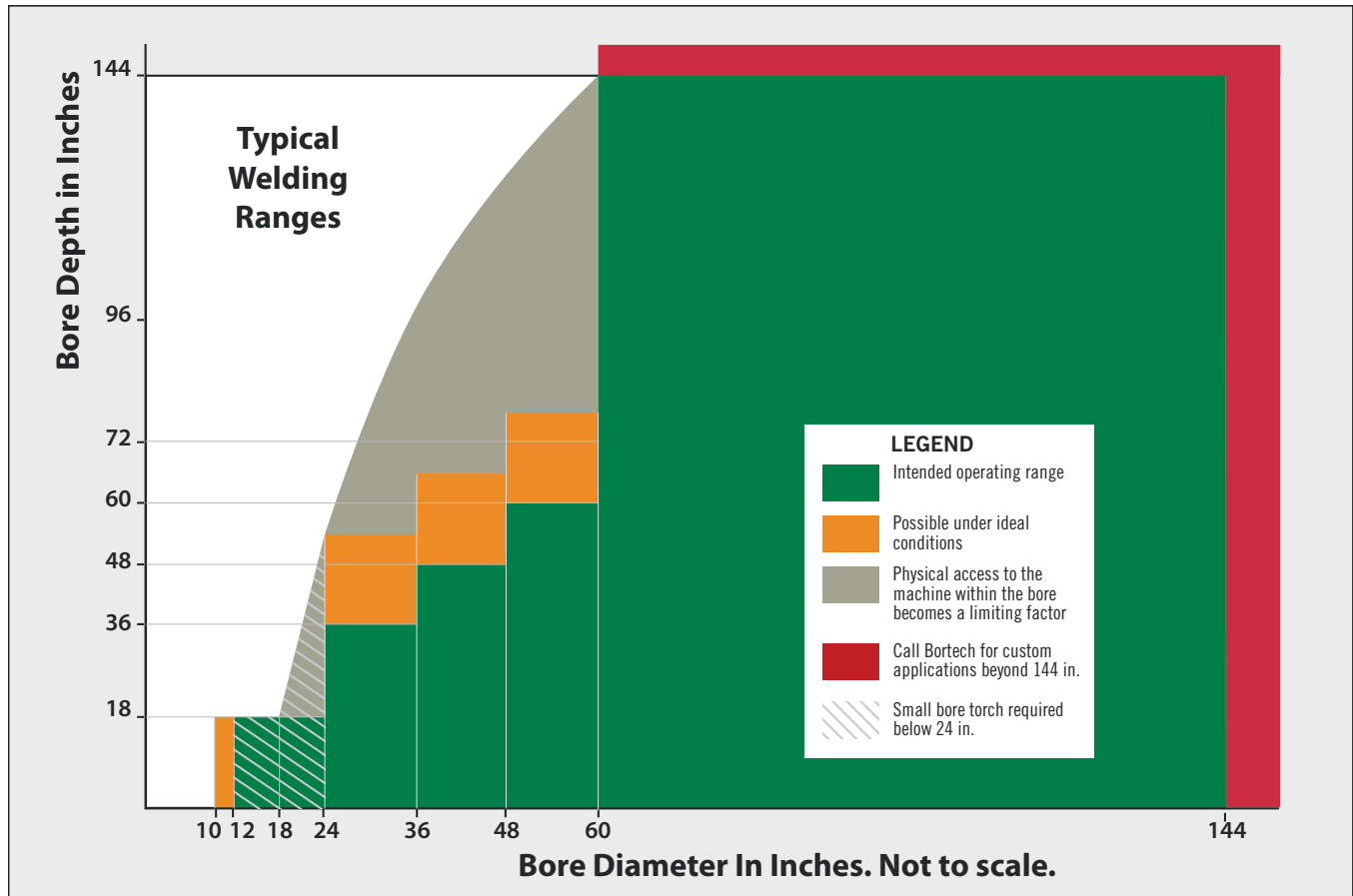

All dimensions should be considered reference. Contact your Climax Representative for precision dimensions. Specifications are subject to change without notice. There are no systems or components on this machine that are capable of producing hazardous EMC, UV or other radiation hazards. The machine does not use lasers nor does it create hazardous materials such as gasses or dust.

# TOOL CONFIGURATIONS

Configure your BW5000 in 6 simple steps:

- 1 Select a Base Unit
- 2 Select Machine Ranges
- 3 Select Controls
- 4 Select Feed Stroke (Auxiliary Slide Guide Rod)
- 5 Select Line Bar
- 6 Select Power Supply Cables
- 7 Select Accessories
- 8 Select Consumables

To generate the correct part number for the machine you require, simply select the part number needed in each step as appropriate, and contact your Climax representative.

**NOTE: Configuration options shown are for vertical axis welding. Please contact us for configuration options to enable horizontal axis (out of position) welding.**

## 1 Base Unit **71991**

Includes: Weld Head, Wire Feed, Wire Feed Conduit & Control Cable, 12 inch (304.8 mm) and 36 inch (914.4 mm) Line Bars, Standard Torch, Stepping Unit, Tool Kit, Packaging, Consumables Package, Positive Weld Cable 25 feet, Shield Gas Hose, and Extra Liner.

## 2 Machine Ranges **72079**

Radial Rod Kit for Welding Range: 24 - 72 inch (609.6 - 1828.8 mm) ID / 24 - 48 inch (609.6 - 1219.2 mm) OD, (includes one each 16, 24 & 38 inch (406.4, 609.6 & 965.2 mm Radial Rod).

Radial Rod Kit for Welding Range: 24 - 96 inch (609.6 - 2438.4 mm) ID / 24 - 72 inch (609.6 - 1828.8 mm) OD, (includes one each 16, 24, 38 & 60 inch (406.4, 609.6, 965.2 & 1524.0 mm) Radial Rod).

Radial Rod Kit for Welding Range: 24 - 120 inch (609.6 - 3048.0 mm) ID / 24 - 96 inch (609.6 - 2438.4 mm) OD, (includes one each 16, 24, 38 & 60 inch (406.4, 609.6, 965.2 & 1524.0 mm) Radial Rod).

Radial Rod Kit for Welding Range: 24 - 144 inch (609.6 - 3657.6 mm) ID / 24 - 120 inch (609.6 - 3048.0 mm) OD, (includes 1 each 16, 24 & 38 inch (406.4, 609.6 & 965.2 mm), two 60 inch (1524.0 mm) Radial Rods and one 96 inch (2438.4 mm) Wirefeed Conduit).

## 3 Controls **71037**

120V Controller with Plastic Connectors **71037**  
 230V Controller with Plastic Connectors **71105**

## 4 Feed Stroke (Auxiliary Slide Guide Rod) Cannot be Combined to Increase Length.

Auxiliary Slide Guide Assembly, 10 inch (254.0 mm) travel **70427**  
 Auxiliary Slide Guide Assembly, 20 inch (508.0 mm) travel **70428**  
 Auxiliary Slide Guide Assembly, 30 inch (762.0 mm) travel **70103**  
 Auxiliary Slide Guide Assembly, 40 inch (1016.0 mm) travel **70429**  
 Auxiliary Slide Guide Assembly, 50 inch (1270.0 mm) travel **70104**

## 5 Line Bar (Depth Into Bore)

Bars cannot be combined for additional length. Base Unit comes with 12 & 36 inch (304.8 & 914.4 mm) line bars.

Line Bar 72 inch (1828.8 mm) **67544**  
 Line Bar 96 inch (2438.4 mm) **72071**

## 6 Power Supply Cables

ESAB 350MPI 14 Pin, 25 feet (7.6 m) **69916**  
 Eutectic Pulsarc 6000 or ESAB LAI 550P, 25 feet (7.6 m) **45490**  
 Lincoln Multi Weld 6 pin, 25 feet (7.6 m) **55327**  
 Lincoln 14 pin, 25 feet (7.6 m) **32042**  
 Miller Millermatic 10 pin, 25 feet (7.6 m) **46670**  
 Miller XMT 14 pin, 25 feet (7.6 m) **34217**  
 Miller 14 pin w/100V Pigtail, 25 feet (7.6 m) **29824**  
 Miller Deltaweld 5 pin, 25 feet (7.6 m) **69918**  
 Blank one end, 25 feet (7.6 m) **36874**  
 Universal, 25 feet (7.6 m) **69920**

## 7 Accessories **71988**

Small Bore Kit, 12 - 24 inch (304.8 - 609.6 mm) ID  
 Conical Seat Step Mechanism, 10 inch (254.0 mm) Stroke (Taper Seat Welding) **70193**

## 8 Consumables

Gas Diffuser for Torch **67547**  
 Nozzle for Torch **67548**  
 Insulator for Torch **67549**  
 Contact Tip 0.045 inch (1.1 mm) **67555**  
 Contact Tip 0.062 inch (1.6 mm) **67557**  
 Feed Roll V-Groove 0.045/0.062 inch (1.1/1.6 mm) **67453**  
 Feed Roll V-Groove 0.045/0.052 (1.1/1.3 mm) + 1/16 Knurled **70488**

# OPERATIONAL DIMENSIONS

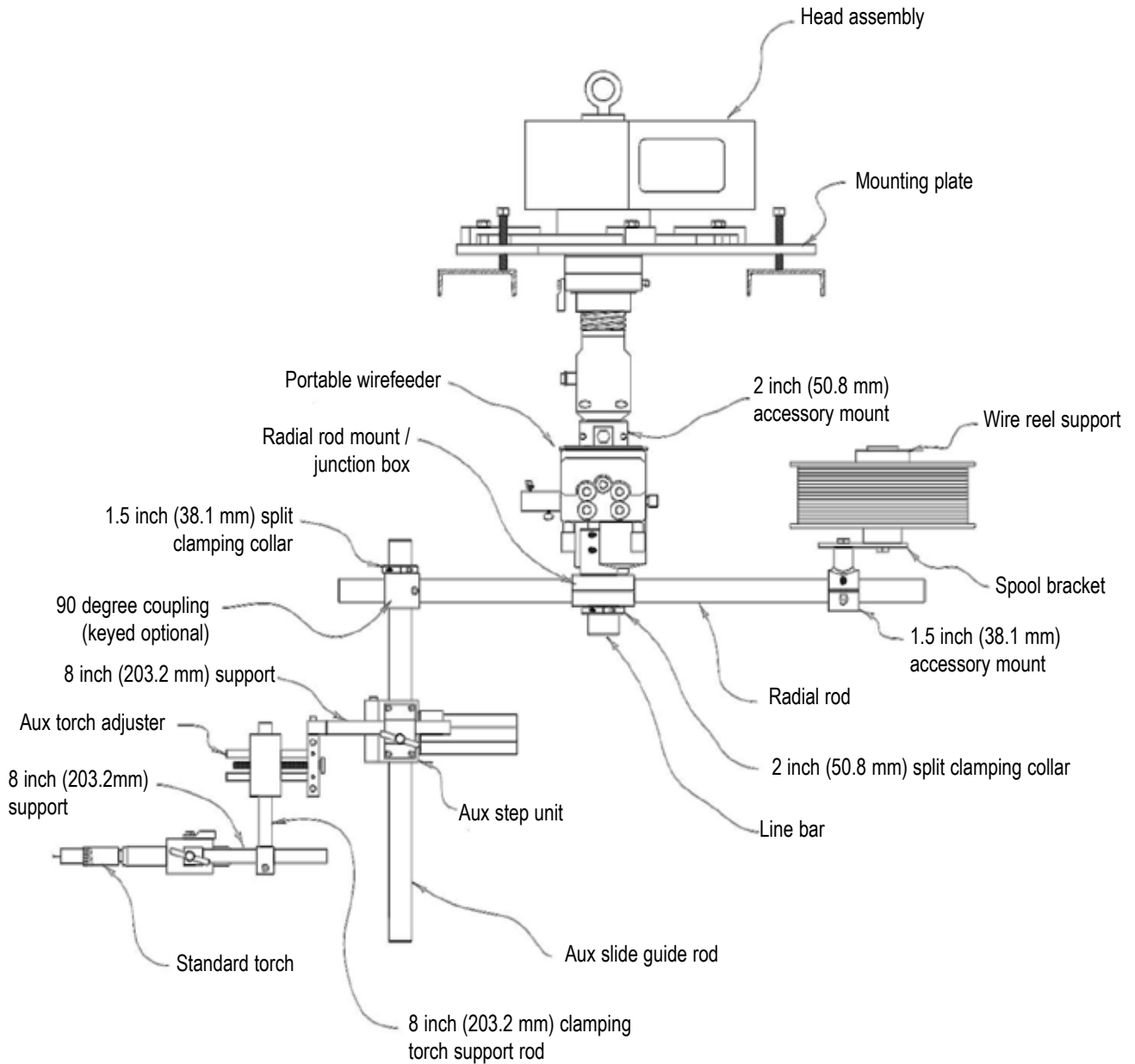

# OPERATIONAL DIMENSIONS

Dimensions in Inch (mm)

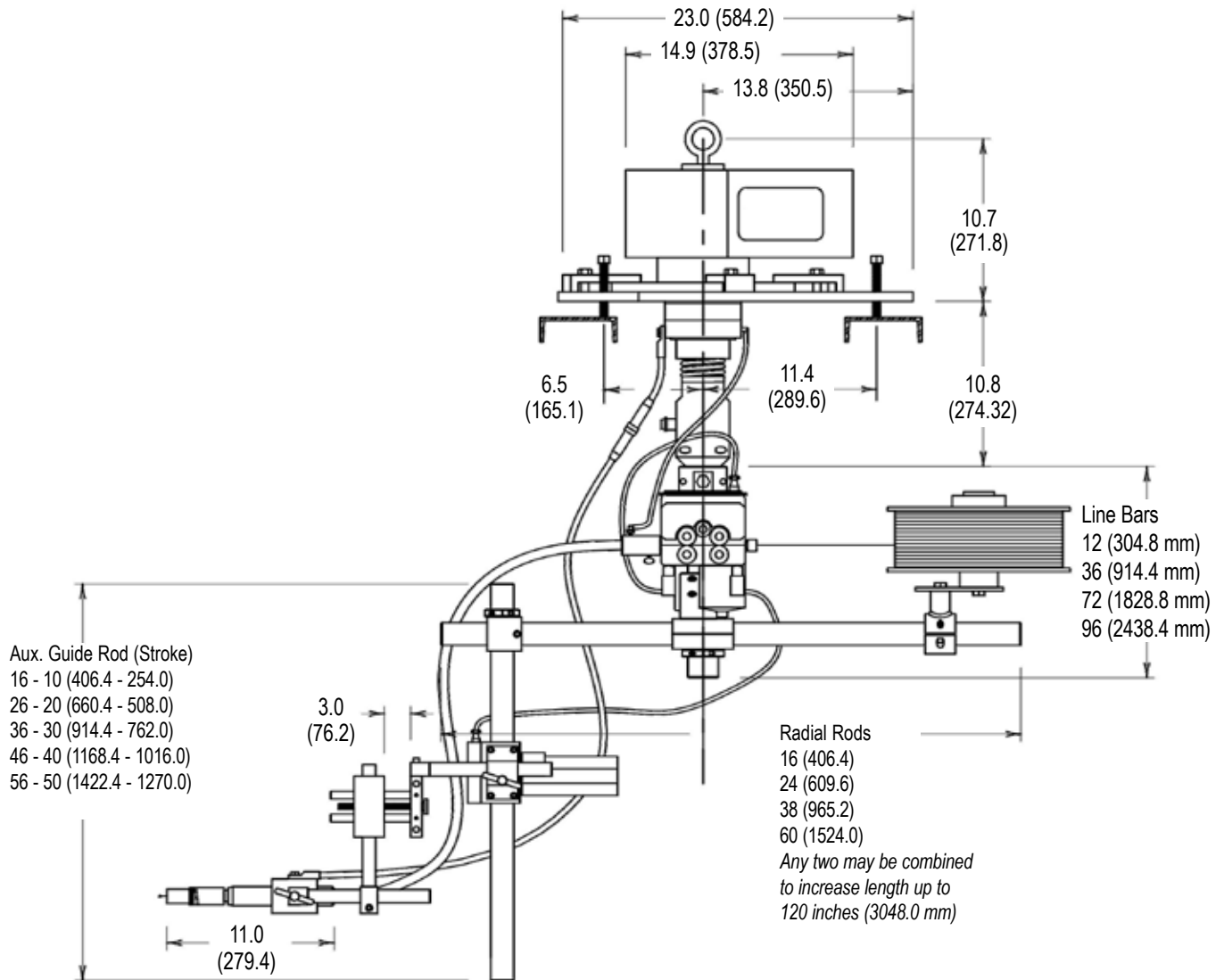

# CLIMAX GLOBAL LOCATIONS



## Call Climax for:

### On-site Training

Need some refresher courses in setting up and operating your CLIMAX machine tool?

### Special Projects

CLIMAX has been solving complicated on-site machining and welding problems for our customers since 1964.

### Rentals

With 16 worldwide rental depot locations, you are never far away from a CLIMAX tool.

Connect with us:  

### World Headquarters

2712 E. Second Street  
Newberg, Oregon 97132 USA  
Worldwide Telephone: 1.503.538.2185  
N. America Toll-Free: 1.800.333.8311  
Fax: 1.503.538.7600  
Email: [info@cpmt.com](mailto:info@cpmt.com)

### European Headquarters

Am Langen Graben 8  
52353 Düren, Germany  
Telephone: (+49) (0) 2421.9177.0  
Fax: (+49) (0) 2421.9177.29  
Email: [info@cpmt.de](mailto:info@cpmt.de)